

Power supply, standard	PSUH: HMI, 1200W, 230VAC
Type of cable gland	ESKVS 20
Material cable gland	Polyamide
Type of cable	non-armoured
Power cable	NYSLYÖ-JZ 5x1,5mm ²
Ø cable diameter min	6 mm
Ø cable diameter max	13 mm
Globe colour	Clear
Mounting	Upside
Weight	51 kg
Tariff number	94054910

Remarks:

SH450: Searchlight with metal halide lamp 1200W, IP56 glass parabolic mirror 450mm
1200W
K(220): Power supply unit, conventional, PSUH, 220V
P08: Cabin Control C 400/450

Equipment:

- Toughened front glass
- Rubber sealing
- Quick fastening devices
- Ignition unit and stand-by heater
- Connection cable 3m
- Anti dazzle screen

Spare parts

SP-S-450 front frame + front glass	22000018
SP-SX/SH-450 Primary mirror	22000019
SP-S-Quick releases clamp (4 pcs)	22000050
SP-SKS-Auxiliary mirror LSH 400/450	22000106
SP-SW-Gasket for searchlight housing	22000116
SP-SH-Metal halide lamp 1200W 230V SFC	22000593
SP-SH450-PSUH-1200W Choke (L1)	22000800
SP-S Folding bellow	22000867

12.05.2026

Your Contact:

WISKA India Pvt. Ltd.

Mr. Omkar Ashar · Unit No.247/248,Raheja Tesla Industrial District II , Edison Bldg No.-1A,
Plot No.GEN2/1/C/PART, TTC Industrial Area, MIDC, Juinagar, Navi Mumbai 400705, India

☎ +91-22-4967-1438 · ☎ +91-22-4967-1439 · o.ashar@wiska.in · www.wiska.in

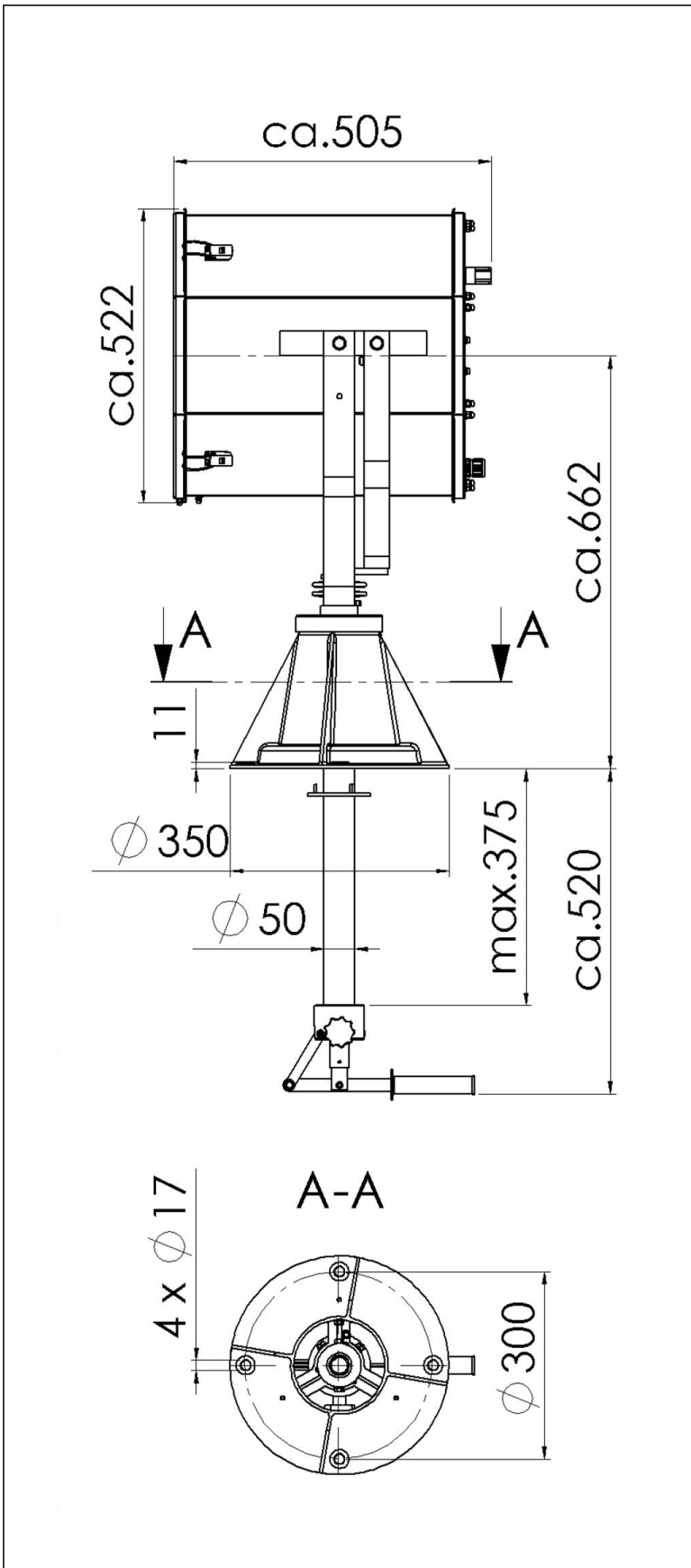

Your Contact:

WISKA India Pvt. Ltd.

Mr. Omkar Ashar · Unit No.247/248,Raheja Tesla Industrial District II , Edison Bldg No.-1A,
Plot No.GEN2/1/C/PART, TTC Industrial Area, MIDC, Juinagar, Navi Mumbai 400705, India

☎ +91-22-4967-1438 · ☎ +91-22-4967-1439 · o.ashar@wiska.in · www.wiska.in



Your Contact:

WISKA India Pvt. Ltd.

Mr. Omkar Ashar · Unit No.247/248,Raheja Tesla Industrial District II , Edison Bldg No.-1A,
Plot No.GEN2/1/C/PART, TTC Industrial Area, MIDC, Juinagar, Navi Mumbai 400705, India

☎ +91-22-4967-1438 · ☎ +91-22-4967-1439 · o.ashar@wiska.in · www.wiska.in

Other technical data on request / subject to change without notice

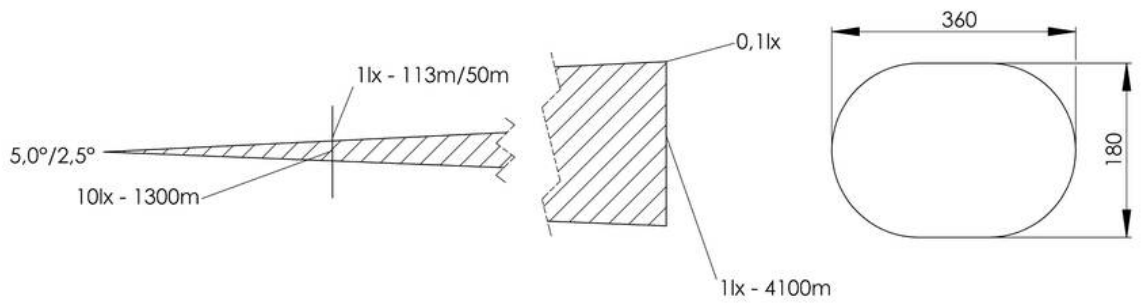

Your Contact:

WISKA India Pvt. Ltd.

Mr. Omkar Ashar · Unit No.247/248, Raheja Tesla Industrial District II , Edison Bldg No.-1A,
Plot No.GEN2/1/C/PART, TTC Industrial Area, MIDC, Juinagar, Navi Mumbai 400705, India

☎ +91-22-4967-1438 · ☎ +91-22-4967-1439 · o.ashar@wiska.in · www.wiska.in

Other technical data on request / subject to change without notice