

SX450 -2000+EI(220)-P10

Searchlight with Xenon lamp Ø 450mm 2000W 230V

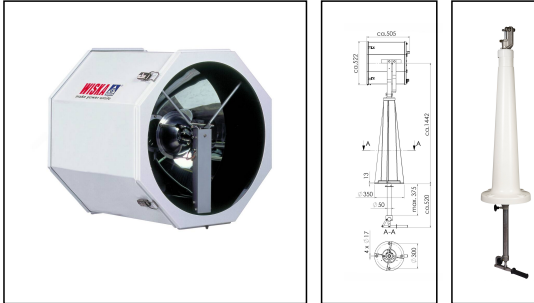

Products may differ in size, colour and appearance to those shown. If you require further information or customisation, please contact us directly.

WISKA-Order no.	10106120
Type	SX450 -2000+EI(220)-P10
Material	Stainless steel
Wattage	2000 W
Colour	RAL 9016
Surface	Powder coated
Voltage	230 V
Type of Voltage	AC
Frequence	50/60 Hz
Protection class	IP56
Operational areas	Outdoor
Reflector	Glass
Focusing	fixed focus
Lightsource	Xenon lamp
Lightsource incl.	Yes
Luminous flux	80000 lm
Average lamp durability	2400 h
Light performance	immediately
Range (1 lux)	9600 m
Light intensity mio/cd	92
Divergence	2,7°/10
Temp. range min	-25 °C
Temp. range max	45 °C
Power supply, electronic	PSUX-E: 2000W indoor
Type of cable gland	M 25 x 1,5

Your Contact:

WISKA India Pvt. Ltd.

Mr. Omkar Ashar · Unit No.247/248,Raheja Tesla Industrial District II , Edison Bldg No.-1A,
Plot No.GEN2/1/C/PART, TTC Industrial Area, MIDC, Juinagar, Navi Mumbai 400705, India

☎ +91-22-4967-1438 · ☎ +91-22-4967-1439 · o.ashar@wiska.in · www.wiska.in

Material cable gland	Brass
Type of cable	non-armoured
Ø cable diameter min	8 mm
Ø cable diameter max	10,5 mm
Globe colour	Clear
Mounting	Upside
Weight	82 kg
Tariff number	94054910

Remarks:

SX450: Searchlight with xenon short arc lamp, 2000W, IP56 glass parabolic mirror 450mm
2000W

EI(220): Electronic power supply unit PSUX-E 50-60Hz operating voltage, inside IP 44 + FAN

P10: Cabin Control with Pedestal, CP 400/450, aluminium

Equipment:

- Toughened front glass
- Rubber sealing
- Quick fastening devices
- Ignition unit
- Stand-by heater
- Connection cable 3m
- Anti dazzle screen

Spare parts

SP-S-450 front frame + front glass	22000018
SP-SX/SH-450 Primary mirror	22000019
SP-SX/SH-450 Auxiliary reflector 100mm	22000020
SP-SX450 Blower kit for searchlight head	22000025
SP-SX450 Thermostat for blower 50°C	22000026
SP-S-Quick releases clamp (4 pcs)	22000050
SP-SW-Gasket for searchlight housing	22000116
SP-SX450 Xenon lamp Kit 2000W (from2012)	22000234
SP-SX450-PSUX-E-V4 Mounting plate 2000W	22000887

12.05.2026

Your Contact:

WISKA India Pvt. Ltd.

Mr. Omkar Ashar · Unit No.247/248,Raheja Tesla Industrial District II , Edison Bldg No.-1A,
Plot No.GEN2/1/C/PART, TTC Industrial Area, MIDC, Juinagar, Navi Mumbai 400705, India

☎ +91-22-4967-1438 · ☎ +91-22-4967-1439 · o.ashar@wiska.in · www.wiska.in

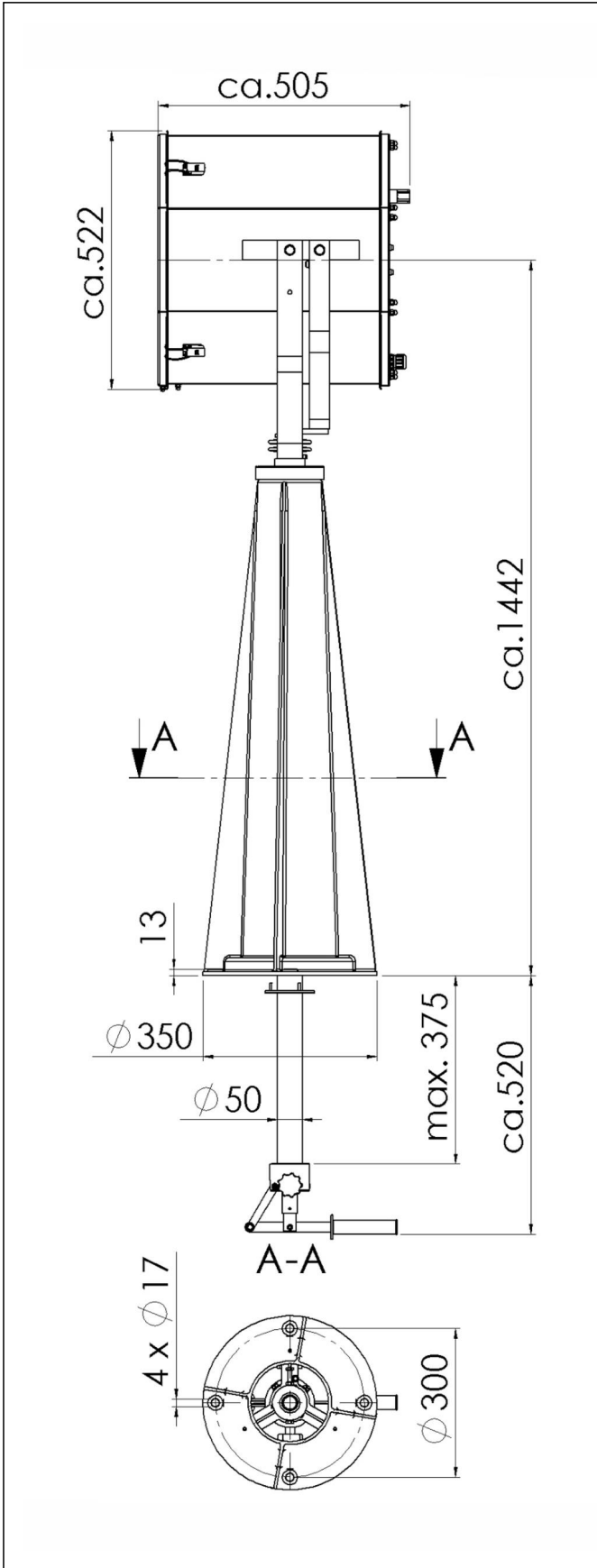

Your Contact:

WISKA India Pvt. Ltd.

Mr. Omkar Ashar · Unit No.247/248, Raheja Tesla Industrial District II , Edison Bldg No.-1A,
Plot No.GEN2/1/C/PART, TTC Industrial Area, MIDC, Juinagar, Navi Mumbai 400705, India

☎ +91-22-4967-1438 · ☎ +91-22-4967-1439 · o.ashar@wiska.in · www.wiska.in