



## OPERATING INSTRUCTIONS

PushIn Mobile Splitter  
for Reefer Container Sockets

# Contents

- 1. ABOUT THESE INSTRUCTIONS ..... 3**
- 1.1 Symbols and guidance signs in these instructions..... 3
- 1.2 Who are these instructions for?..... 3
- 2. SYSTEM DESCRIPTION ..... 4**
- 2.1 The system components..... 5
- 3. DESCRIPTION ..... 6**
- 3.1 Casing..... 6
- 3.2 CEE socket insert..... 6
- 3.3 LED unit ..... 6
- 3.4 Locking system..... 7
- 3.5 Circuit-breaker ..... 8
- 4. REPAIR AND MAINTENANCE..... 9**
- 4.1 Maintenance..... 9
- 4.2 Repair ..... 9
- 4.3 Replacement of the CEE-socket plug-in unit ..... 9
- 4.4 Replacement of the MCCB ..... 12
- 4.5 Replacing the housing seal (seal between housing and cover) 15
- 5. ELECTRICAL CIRCUIT DIAGRAMS ..... 17**
- 5.1 Circuit diagram ..... 17
- 6. DNV GL TYPE APPROVAL ..... 18**

## 1. About these instructions

### 1.1 Symbols and guidance signs in these instructions



**Danger!** There is a risk to life and limb if the warning is not followed.



**Risk of electric shock!** There is a risk to life and limb from electricity if the warning is not followed.



**Use disposable gloves!** Use disposable gloves for the following work to protect the material or your health.



**Attention!** There is a risk to the environment and the device if the warning is not followed.

1, 2, 3, ... **Operating steps** that should take place in a certain order, are numbered sequentially.

- **Operating steps**, that only consist of one step or that don't have to be followed in a certain sequence, are marked with a point.



**Feedback** from executed actions begins with an arrow.



**Enumerations** begin with an enumeration line.

### 1.2 Who are these instructions for?

These instructions are intended for the personnel assigned with the assembly, operation, and maintenance of the reefer container sockets.



**Risk of electric shock!** A qualified electrician may only carry out all electrical installation and repair work!

## 2. System description

The PushIn Mobile Splitter is an extension socket for providing additional electrical connections, for example for thermal containers on sea-going vessels, riverboats and in port systems.

It is suitable for 440V±10% 3-phase. A maximum of 32 A is available in total for the two outlets. The maximum current per outlet is 20 A.







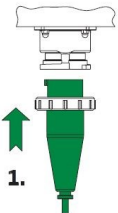

**Caution:** individual thermal containers can require a current of more than 20 A or power of up to 18.75 kVA.

Each socket is protected against short circuits and overloads by an in-built circuit-breaker . The circuit-breaker trips automatically and must be manually returned to the Off or On Position.

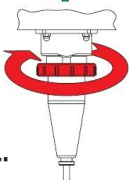
PushIn Mobile Splitter is an internationally standardized CEE socket device compliant with IEC 60309-1 (DIN EN 60309-1; VDE 0623-1), IEC 60309-2 (DIN EN 60309-2; VDE 0623-2)

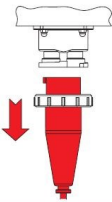
### Important information for use with thermal containers:

When using with thermal containers, the user must ensure that they operate without error with the lower output power of 15kVA or the maximum current of 20 A in single mode. In two-way mode a maximum of 18.75 kVA is available for both outlets together. Always insert the PushIn Mobile Splitter into a socket first and then connect the outlet sockets one after the other.

JUST PUSH IN AND FASTEN BAYONET RING!			<b>READ THE MANUAL BEFORE USE!</b>  <b>DO NOT OPEN WHILE VOLTAGE IS PRESENT</b>
<b>ON</b>  1.	 2.	 2.	
<b>OFF</b>  1.	 2.	 2.	
 <b>ALWAYS FASTEN BAYONET RING AFTER PUSH IN!</b>		<b>2x20A ONLY</b>  <b>WISKA</b> <small>make power smile</small>	

## 2.1 The system components

- The system consists of system components:
- Casing with cable gland(s)
- Cover
- CEE socket insert (A) with plug contact sleeves (B), circuit-breaker (C), LED circuit board (D), bayonet cap (E) and mechanical functional elements (F)
- Internal wiring
- Terminals

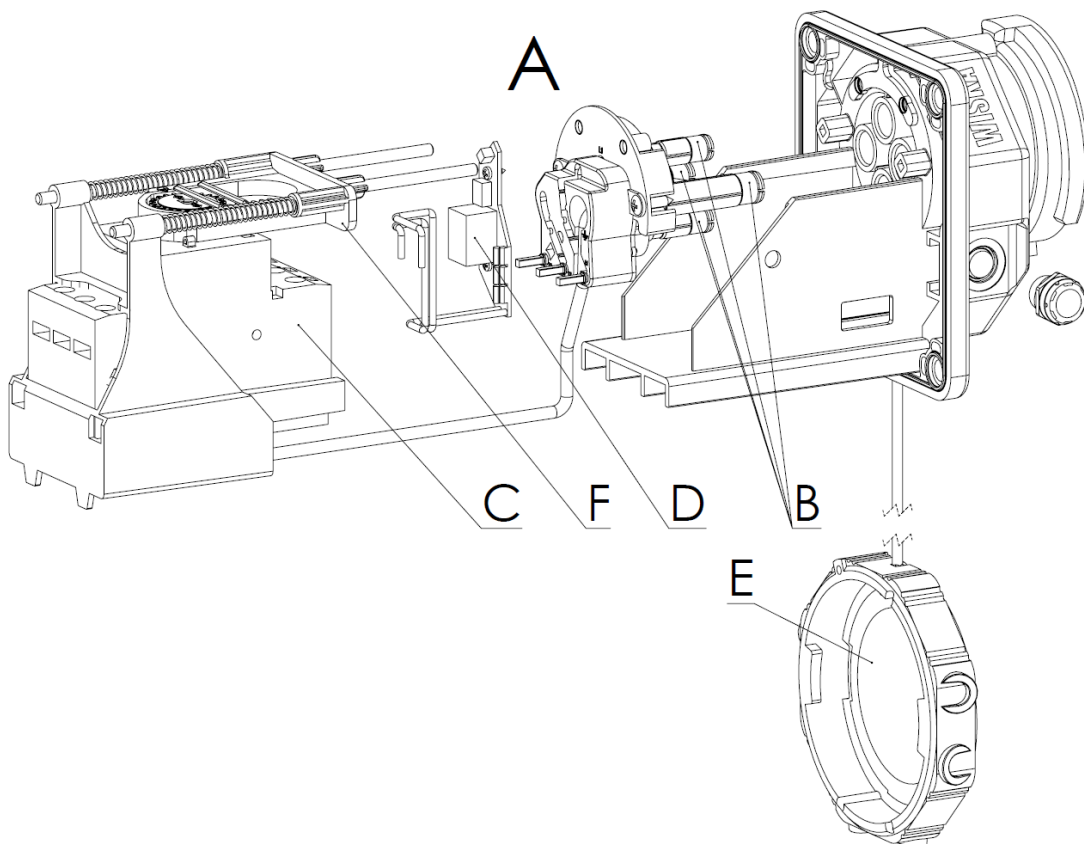

Figure 1: Depiction of a CEE socket insert

## 3. Description

### 3.1 Casing

The casing consists of powder coated (color as requested by customer) welded stainless steel sheet with welded bolts for fixing the components. In order to ensure the degree of protection IP 67 according to EN 60529, a high quality rubber seal is pressed onto the upper bent section of the housing.

Fixing lugs on the housing floor are used to fix the equipment.

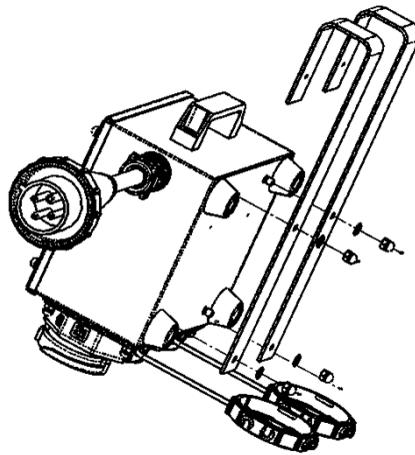

### 3.2 CEE socket insert

The CEE socket insert consists of a CEE socket with the contact sleeves (3-phase sleeves with an earth sleeve), the circuit-breaker (see 1.2.4), the bayonet cap, the cables and the mechanical actuating elements. Furthermore, the LED unit and, as an alternative, a pressure compensating element, are installed inside.

The groove for preventing incorrect connection of the CEE socket in respect of the protective conductor contact defines the voltage and frequency. VARITAIN PushIn is offered and delivered in its 3-hour setting as standard.

### 3.3 LED unit

The LED unit is installed in the CEE socket insert and serves as a status signaling element, indicating that the circuit-breaker has switched. When the LED unit lights up green, the circuit-breaker is switched on and power is supplied to the CEE socket. The LED unit does not check whether power is supplied to all three phases.

If the LED unit does not light up, there is no power at the CEE socket.

### 3.4 Locking system

According to the international regulations the plug can only be plugged in and withdrawn in the switched off state of the circuit-breaker.

Operation mode:

#### Power On

Turn the bayonet cap anticlockwise and remove it.



Insert the plug into the socket as far as it will go.  
→ The socket is switched on!



Push the bayonet ring over the socket and tighten it firmly in a clockwise direction.

#### Power Off

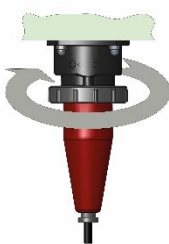

Release the bayonet ring of the plug by turning it anticlockwise.

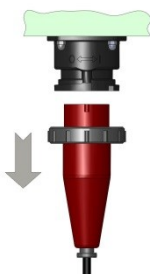

Pull the plug out of the socket.  
→ The socket is switched off!

Tighten the bayonet cap by turning it clockwise.

**Attention:**

Please ensure that you only use plugs that conform with international standards [IEC 60309-1 (DIN EN 60309-1; VDE 0623-1), IEC 60309-2 (DIN EN 60309-2; VDE 0623-2)] are used, as only in this way is the safe operation of the plug device is ensured. Please particularly ensure that:

- the plug housing is undamaged
- the bayonet ring is present with undamaged seal
- the plug is clean and dry
- the auxiliary protrusion of the plug is present
- the plug is connected in accordance with the valid standards

### 3.5 Circuit-breaker

Number of poles: 3

Short circuit switch-off capability: Standard 25 kA

Rated insulation voltage: 630 VAC

Rated current: max. 20 A

The circuit-breaker is fitted with a trip knob that mechanically simulates tripping, as for e.g. a short circuit or overload.

## 4. Repair and maintenance

### 4.1 Maintenance

No maintenance is provided in addition to the regular checking of the contact sleeves (unavoidable wear caused by high numbers of plugging cycles and by dirty or faulty plugs).

### 4.2 Repair



**Attention:**

The housing may not be opened when under voltage and only by trained staff. Safety measure to DIN VDE 0105

- Disconnect
- Shield unit from restart
- Verify disconnected parts are free of voltage
- Ground an by-pass
- Protect and separate the energised components near by.



Repair / reconditioning work may only be undertaken using WISKA original spare parts. Changes or alterations to the equipment are not permitted.

### 4.3 Replacement of the CEE-socket plug-in unit



**Precautionary measures**

Switch the entire equipment to the no-voltage state. Remove the cover and check whether the equipment has been switched to the no-voltage state with a voltmeter. Ensure that the equipment is not re-activated while working

- Release the three upper screw terminals of the circuit-breaker and pull the three cables out of the screw terminals

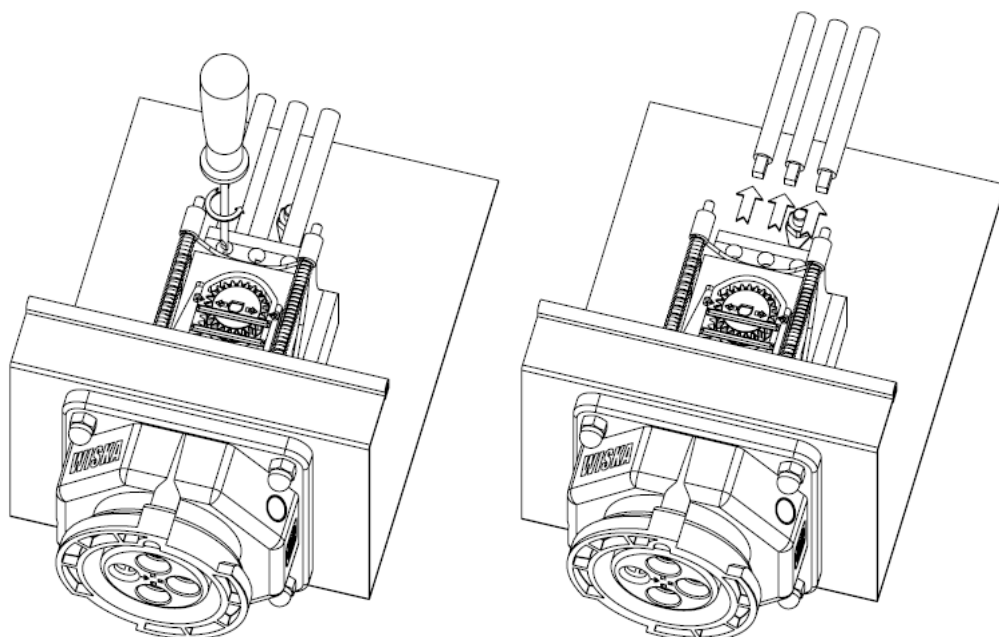

- Release the earth connection

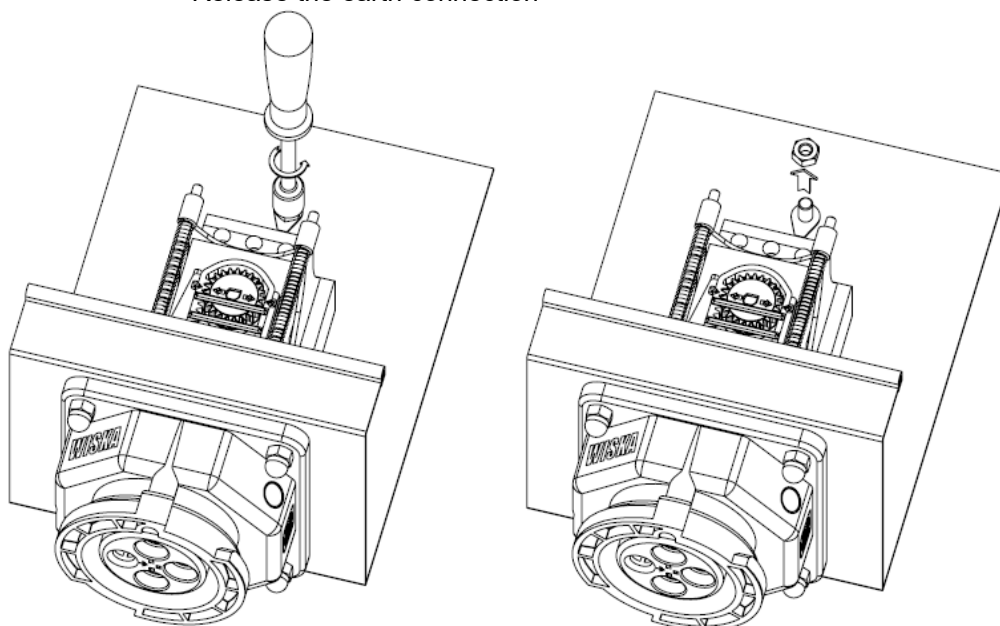

- Remove the four cap nuts with a hexagonal spanner of spanner width 10

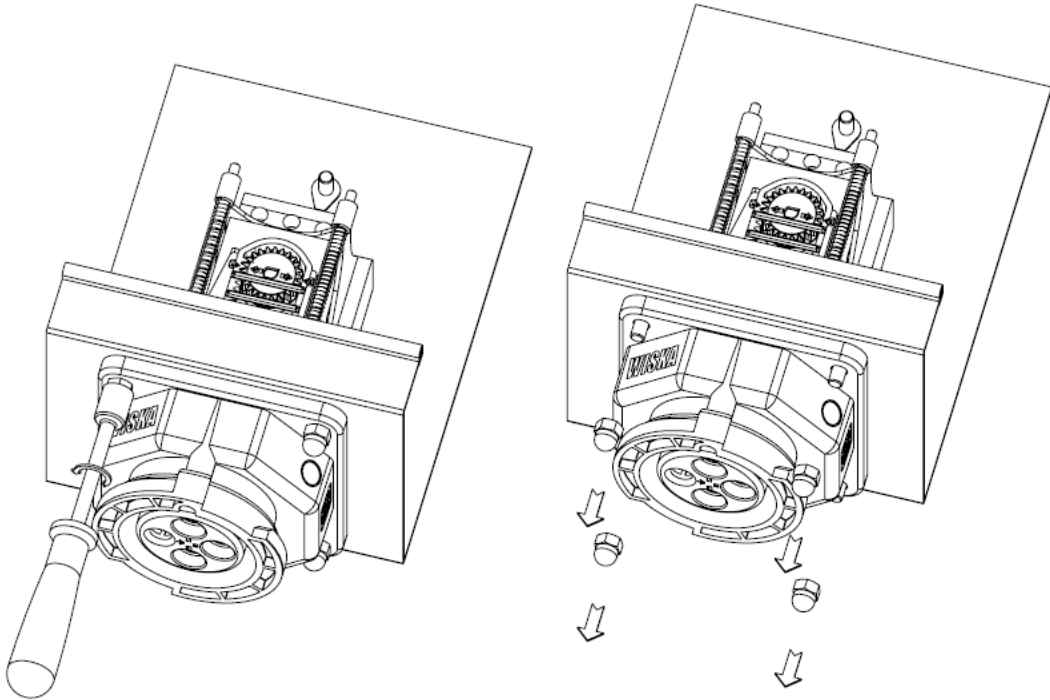

- Remove the CEE-socket plug-in unit by pulling it forward

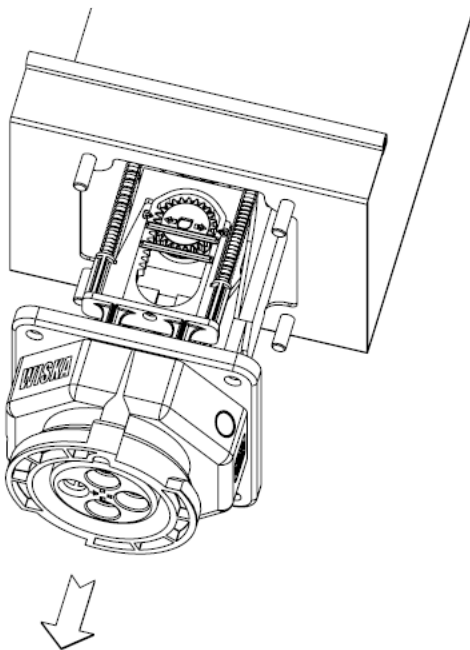

### Installing the socket interior

- In the reverse order.



**Please make sure that the seal is properly emplaced.**

**The cap nuts should be tightened with a torque of 3,5 Nm.**

**The earth connection should be fitted first for safety reasons.**

**Consider the polarity of the connections when re-fitting. The following torques apply for the terminal points on the circuit-breaker:**



- 1,7 Nm

## 4.4 Replacement of the MCCB



### Precautionary measures

**Switch the entire equipment to the no-voltage state. Remove the cover and check whether the equipment has been switched to the no-voltage state with a voltmeter. Ensure that the equipment is not re-activated while working.**

- Perform step 1 to step 7 as for the replacement of the CEE socket insert
- Disconnect the two cables of the LED unit from the circuit-breaker (see 2.2.2)
- Loosen the clamp block's lateral guide, pull the clamp block back, and remove the insert assembly.

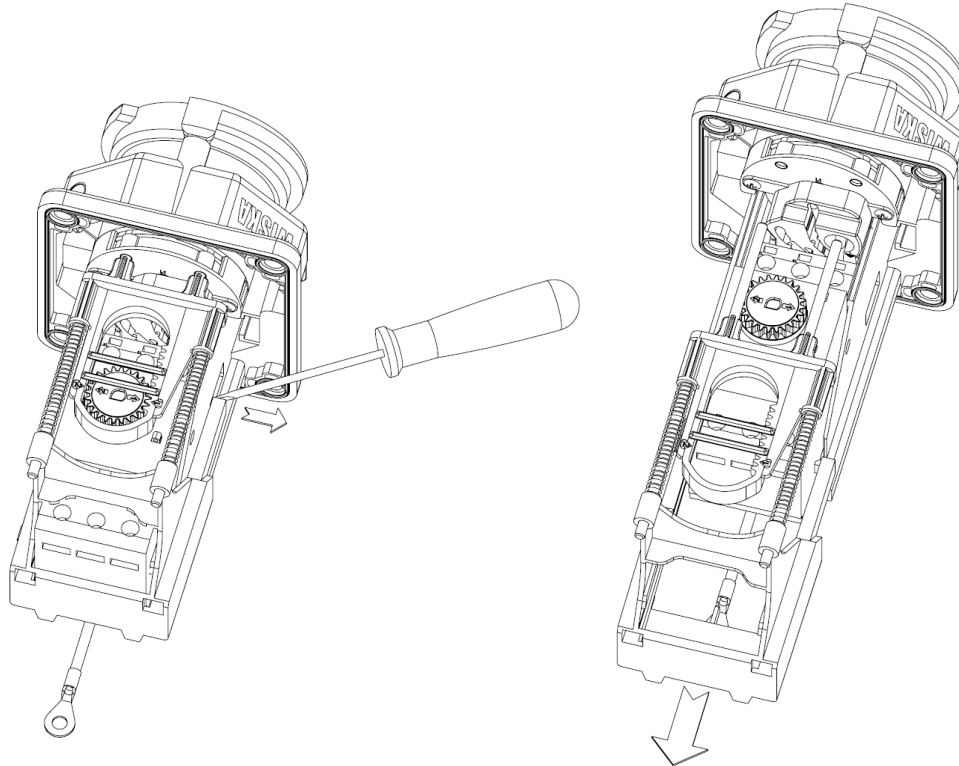

- Release the three upper screw terminals of the circuit-breaker and remove the MCCB

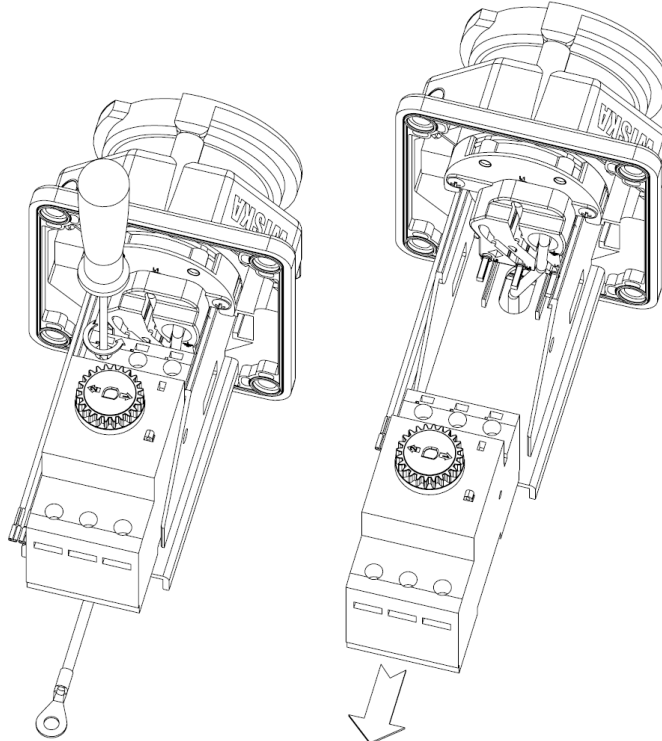

## Installing the MCCB

- in the reverse order



**Please make sure that the seal is properly emplaced.  
The cap nuts should be tightened with a torque of 4,5 Nm.  
The earth connection should be fitted first for safety reasons.  
Consider the polarity of the connections when re-fitting.**



**Achten sie darauf, dass alle Bauteile in ihrer entsprechenden Lage sind.  
The following torques apply for the terminal points on the circuit-breaker:**

- 1,7 Nm

## 4.5 Replacing the housing seal (the seal between housing and cover)

- Remove the old seal (L).
- Cut the seal to size at least 100 mm longer than required.
- Apply adhesive WeiconContact VA 2500HT over the entire length to the inner side of the seal



- Firmly press the seal on to the inner edge of the opening aperture of the housing.



- Press the seal into the curves of the inner edge.



- Cut off the seal leaving an overhang of 3-5 mm.



- Apply the adhesive WeiconContact VA 8312 to the profile of the seal.

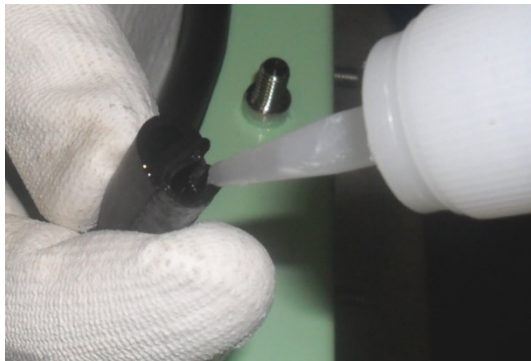

- Press the ends of the seal together and press the seal firmly onto the housing's inner edge.



**Only careful joining and sticking of the two seal ends guarantees a functional seal.**



**Please obtain the article and order numbers of the individual components from the separate, order-specific spare parts list.**

## 5. Electrical circuit diagrams

### 5.1 Circuit diagram

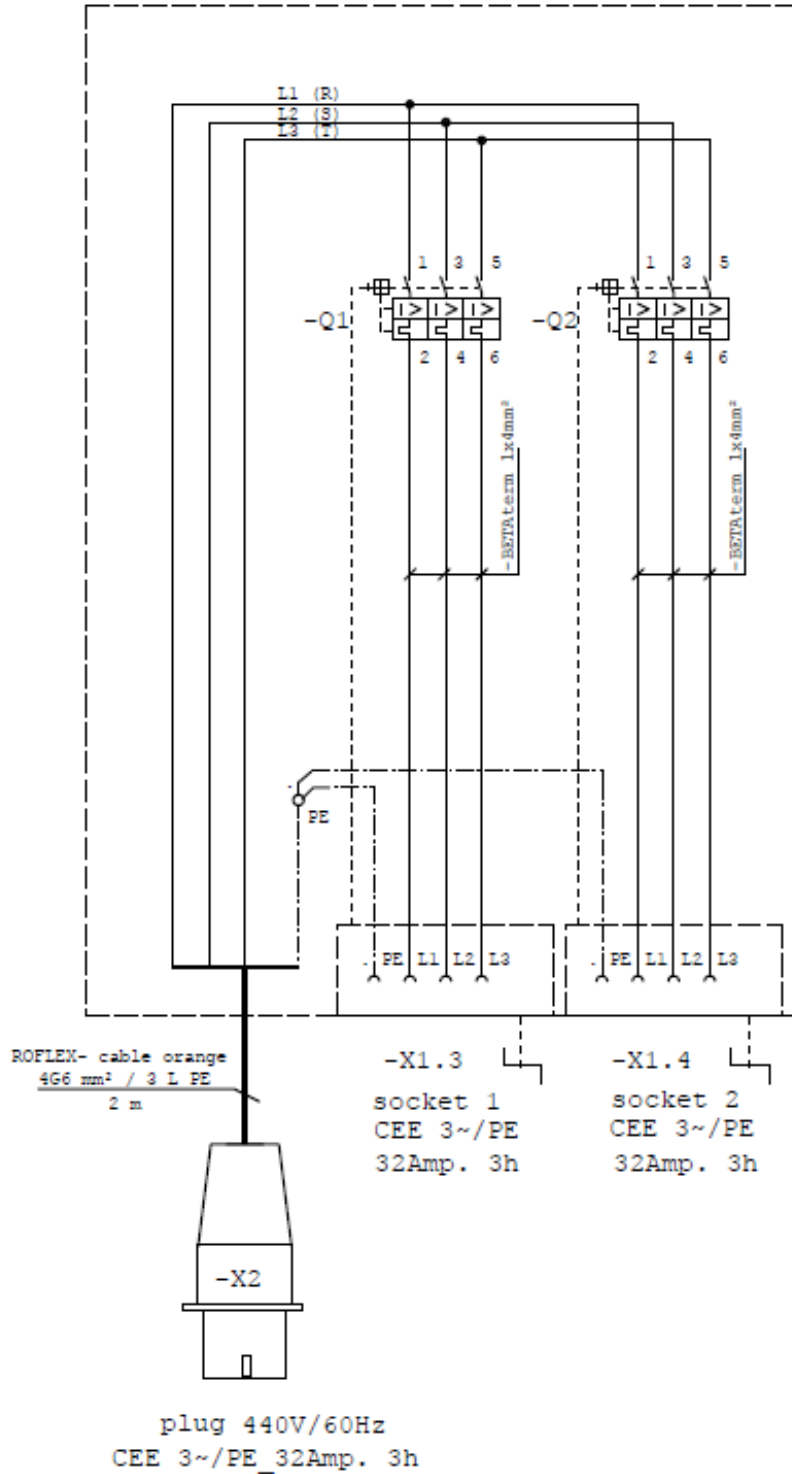

## 6. DNV GL Type Approval



**DNV-GL**

Certificate No:  
**TAE00002AX**  
Revision No:  
**1**

# TYPE APPROVAL CERTIFICATE

**This is to certify:**

**That the Socket Outlet**

with type designation(s)  
**Push In Mobile Splitter with 2 Socket Outlets, PushIn Mobile Extension**

Issued to  
**WISKA Hoppmann GmbH**  
**Kaltenkirchen, Germany**

is found to comply with  
**DNV GL rules for classification – Ships, offshore units, and high speed and light craft**

**Application :**

**Product(s) approved by this certificate is/are accepted for use on all vessels classed by DNV GL.**

Type	Rated voltage (V)	Rated current (A)	Degree of protection
<b>Push In Mobile Splitter with 2 Socket Outlets</b>	<b>440 V AC</b>	<b>32</b>	<b>IP56 / IP67</b>
<b>PushIn Mobile Extension</b>	<b>440 V AC</b>	<b>32</b>	<b>IP56 / IP67</b>

Issued at **Hamburg** on **2019-11-21**

This Certificate is valid until **2024-11-20**.

DNV GL local station: **Hamburg**

Approval Engineer: **Uwe Supke**



for **DNV GL**

Digitally Signed By: **Schaarmann, Arne**  
Location: **DNV GL SE Hamburg, Germany**  
Signing Date: **2019-11-21**

**Arne Schaarmann**  
**Head of Section**

This Certificate is subject to terms and conditions overleaf. Any significant change in design or construction may render this Certificate invalid. The validity date relates to the Type Approval Certificate and not to the approval of equipment/systems installed.



Form code: TA 251

Revision: 2016-12

www.dnvgl.com

Page 1 of 2

© DNV GL 2014. DNV GL and the Horizon Graphic are trademarks of DNV GL AS.

empty page

**WISKA Hoppmann GmbH**

Kisdorfer Weg 28  
24568 Kaltenkirchen  
Germany

 +49 (0) 4191-508-0

 +49 (0) 4191-508-129

sales@wiska.de

[www.wiska.com](http://www.wiska.com)